

ITEM NO.	Product Code	DESCRIPTION	Extended/QTY.
1	BPCST3000RPB-1.2	3000L Slimline Tank	1
2	CPAS2K	Cover Plate Adblue Sgls HDPE-2KL	1
3	SL4-NV	255mm Screw Lid- Non Vented	1
4	CPA420	HDPE Cover Plate	1
5	SW1	Spinweld	2
6	MBV25M	Labyrinth Breather Vent 1 Inch	2
7	-	Tube Press Fill Line Assembly	1
8	PPIPESUP-SM-F	PIPE SUPPORT	2
9	LHO2SS	Outlet 50mm SS	1
10	SSBV2	Ball Valve 50mm SS	1
11	-	HDPE Cover Plate	1
12	LLI-CR-F	Liquid Level Indicator PVC	1
13	-	HDPE Mounting Block	3

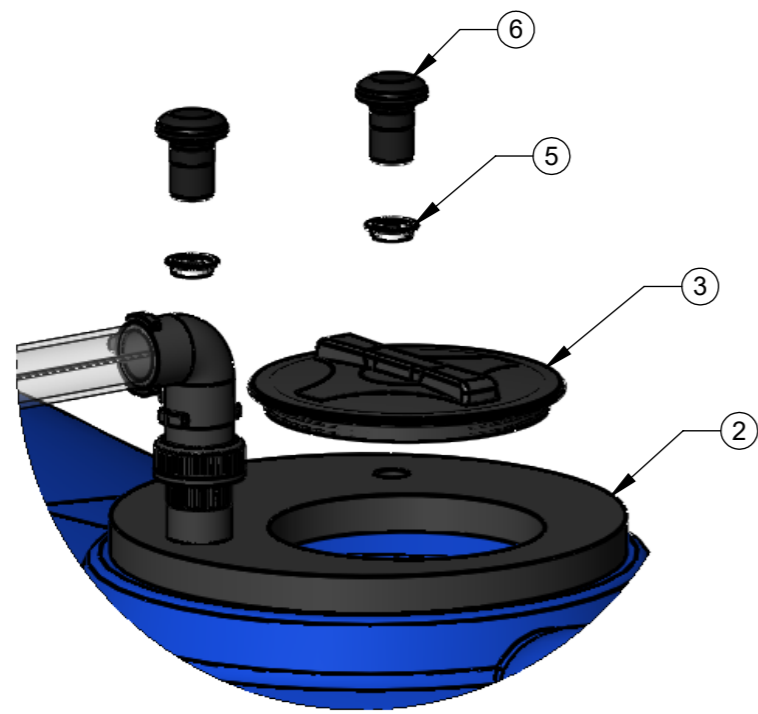

DETAIL A  
SCALE 1 : 6

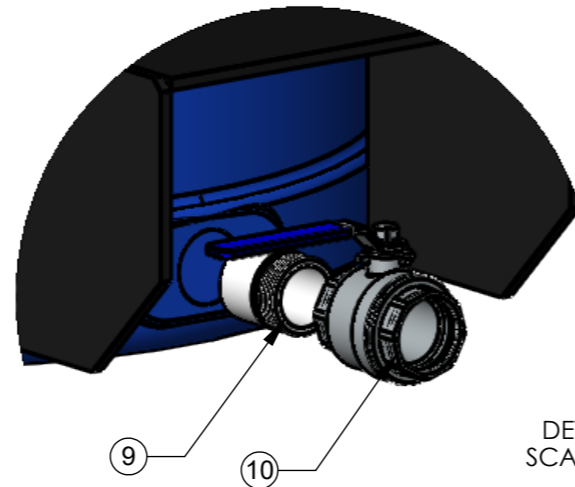

DETAIL B  
SCALE 1 : 6

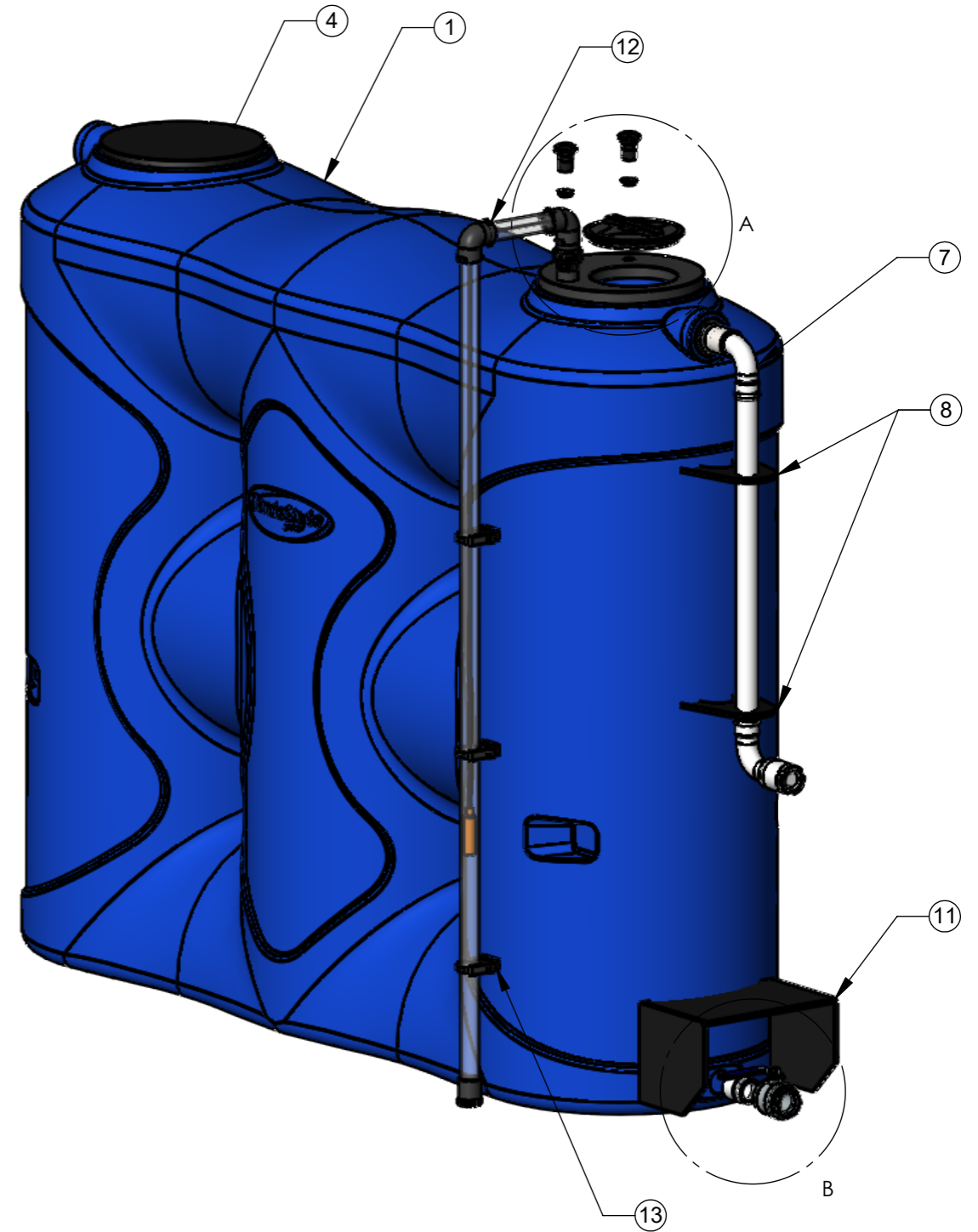



REV	DRAWN	DATE	PARTICULARS
A	AC	23-Apr-19	Created Drawing

ALL TOLERANCES UNLESS OTHERWISE STATED  $\pm 10\text{mm} / \pm 1^\circ$

**Polymaster**  
 161 KARINE STREET  
 SWAN HILL, VIC  
 3585  
 Ph. (03) 5033 9000  
 Fx: (03) 5033 0224

© POLYMASTER GROUP

DESCRIPTION		DO NOT SCALE, USE DIMENSIONS. ALL DIMENSIONS ARE IN mm	
Adblue Slenda Tank 3000l RPB SG1.2		A3 SHEET SIZE	
PRODUCT CODE BMSL3000RPB		SCALE: 1:50	
MATERIAL HEXATHENE 7032		 	
COLOUR RAPID BLUE		DRAWN AC	
LEVEL AS	DRAWING No.	23-Apr-19	1/4 Rev: A

DRAWN	AC	23-Apr-19	1/4 Rev: A
-------	----	-----------	------------

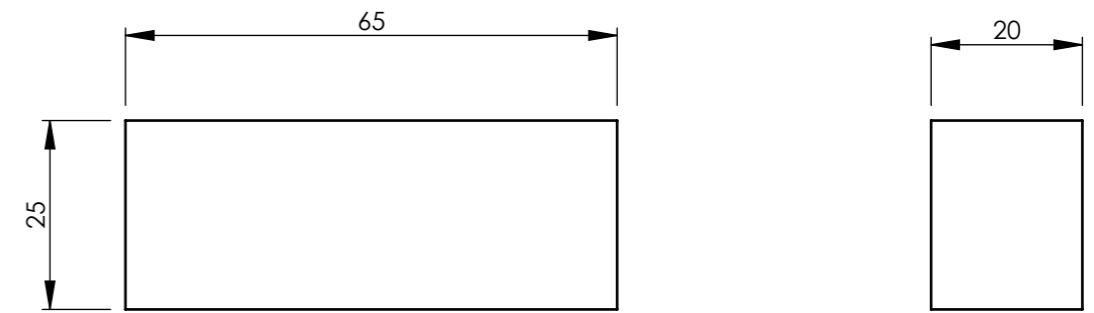
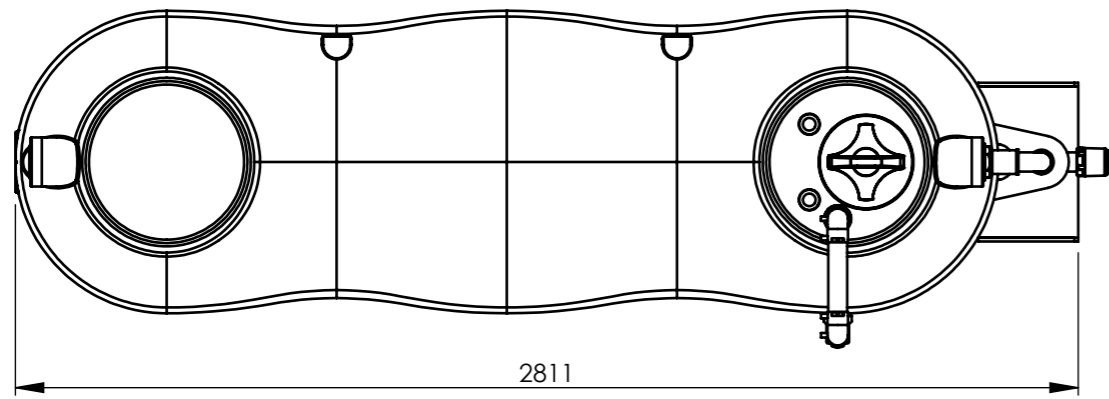

HDPE MOUNTING BLOCK - PART No. 13

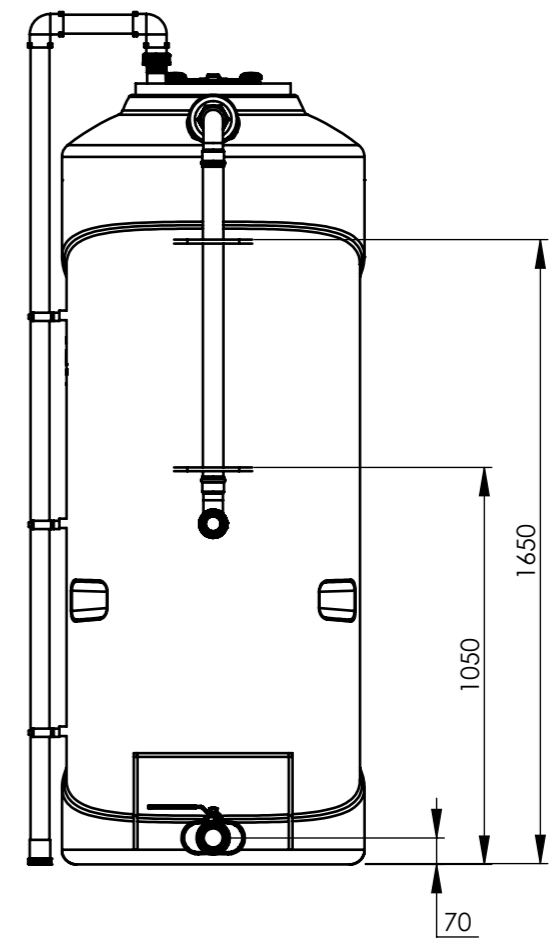
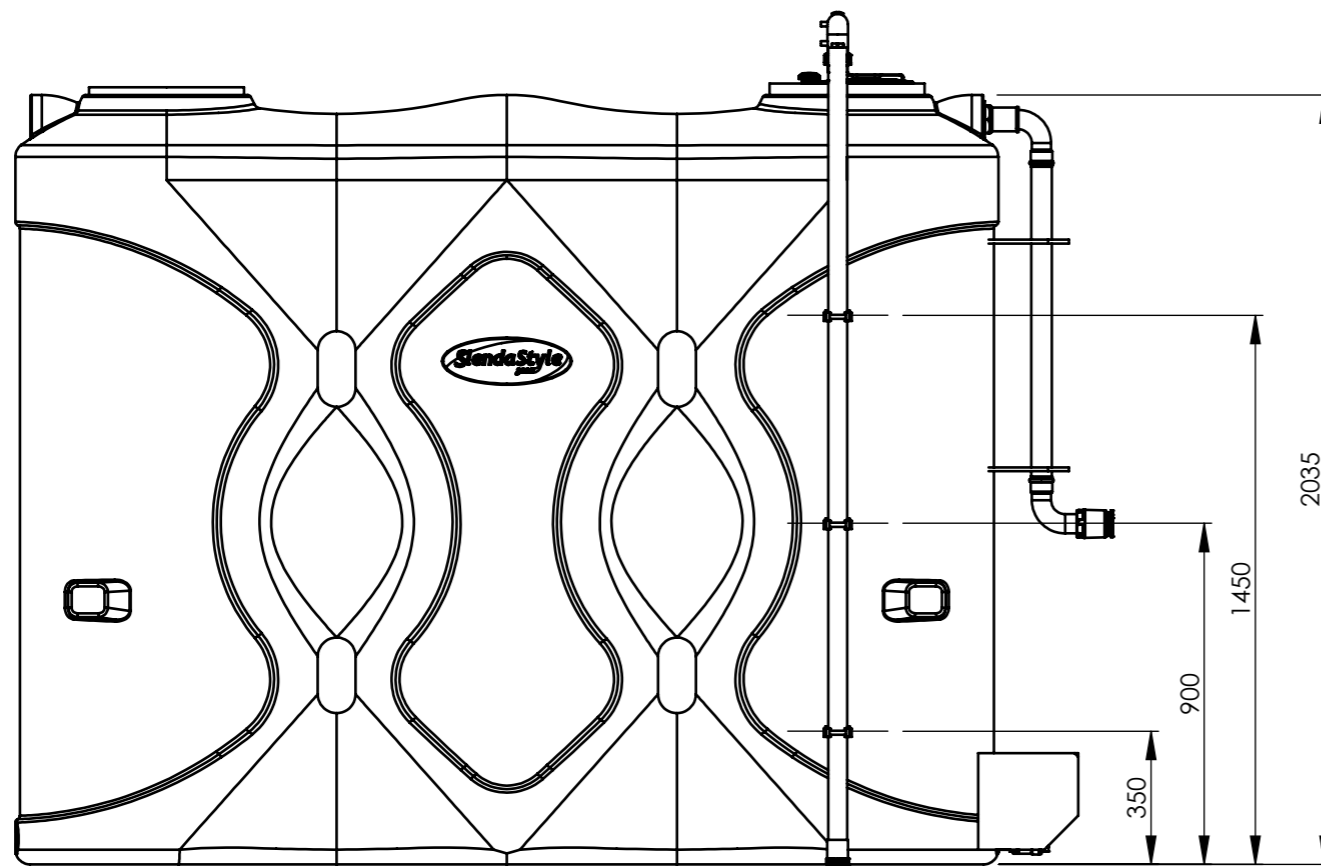

REV	DRAWN	DATE	PARTICULARS
A	AC	23-Apr-19	Created Drawing

ALL TOLERANCES UNLESS OTHERWISE STATED  $\pm 10\text{mm} / \pm 1^\circ$

**Polymaster**

161 KARINE STREET  
SWAN HILL, VIC  
3585  
Ph. (03) 5033 9000  
Fx: (03) 5033 0224



© POLYMASTER GROUP

DESCRIPTION		DO NOT SCALE, USE DIMENSIONS. ALL DIMENSIONS ARE IN mm		
Adblue Slenda Tank 3000l RPB SG1.2		<b>A3</b> SHEET SIZE DRAWN AC 23-Apr-19 2/4 Rev: A		
PRODUCT CODE				BMSL3000RPB
MATERIAL				HEXATHENE 7032
COLOUR				RAPID BLUE
LEVEL	AS	DRAWING No.	BMSL3000RPB-001	

SCALE: 1:20

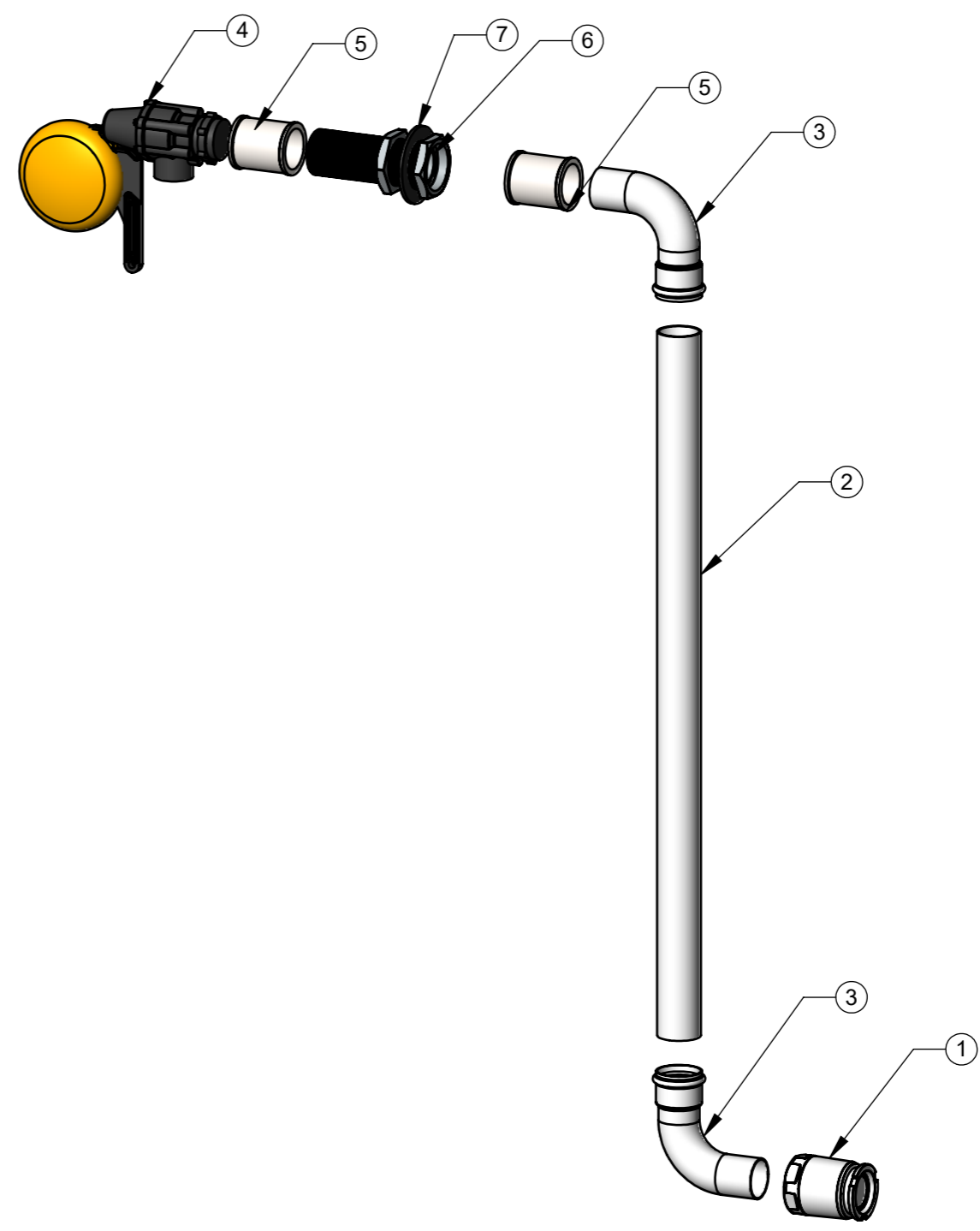
ITEM NO.	Product Code	DESCRIPTION	Fill Line BMSL2000/Extended/QTY.
1	DBA50	Dry Break Adaptor Male 50NB	1
2	TPTUBE54	Tube Press Tube SS 900mm-Long	1
3	TPELFM5450C	Elbow Tube Press 90D F 54MM X 50	2
4	JFV50	50mm Jobe Valve	1
5	HS50SS	2" SS Socket	2
6	AT50SSSET	Pipe All Thread 50 X 150mm+ Nuts	1
7	EPDM50MM	Washer 50mm EPDM	1



				ALL TOLERANCES UNLESS OTHERWISE STATED $\pm 10\text{mm} / \pm 1^\circ$		DO NOT SCALE, USE DIMENSIONS. ALL DIMENSIONS ARE IN mm							
				 161 KARINE STREET SWAN HILL, VIC 3585 Ph. (03) 5033 9000 Fx: (03) 5033 0224 © POLYMASTER GROUP		DESCRIPTION		Tube Press Fill Line Assembly		A3 SHEET SIZE  			
						PRODUCT CODE		-					
						MATERIAL		N/A					
						COLOUR		N/A					
A	AC	23-Apr-19	Created Drawing	LEVEL		SA	DRAWING No.	BMSPIPE-001	DRAWN	AC	23-Apr-19	3/4	Rev: A
REV	DRAWN	DATE	PARTICULARS										

ITEM NO.	Product Code	DESCRIPTION	Extended/QTY.
1		HDPE Valve Side Cover	2
2	-	HDPE Valve Top Cover	1

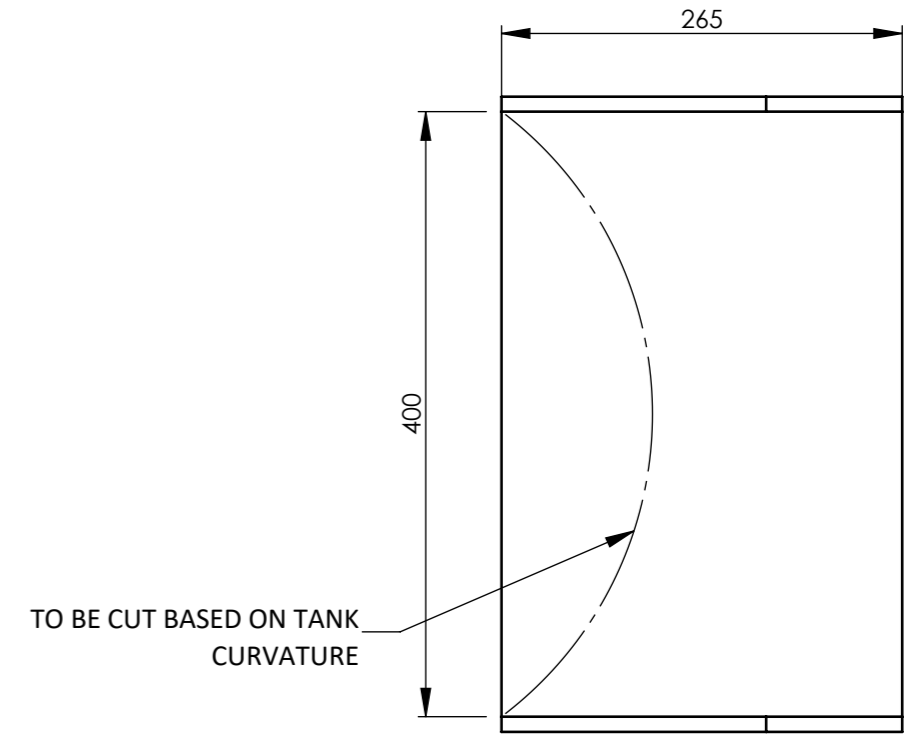
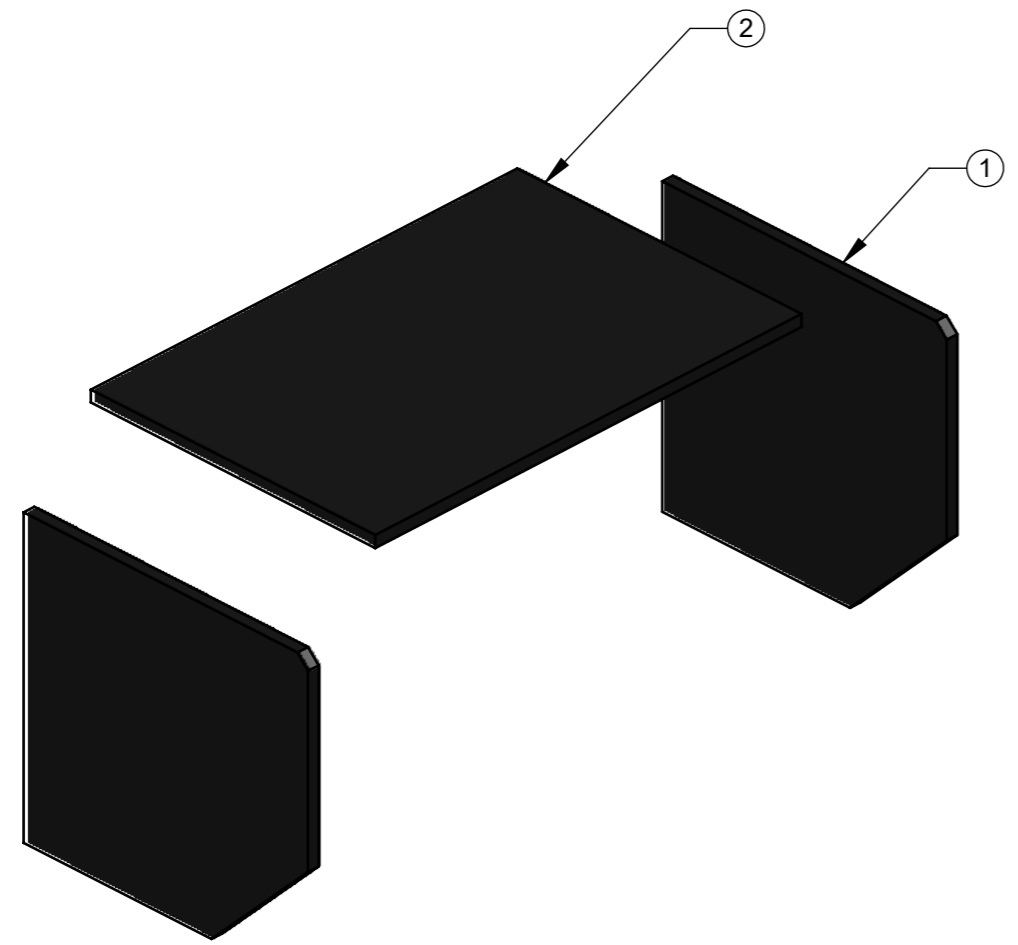
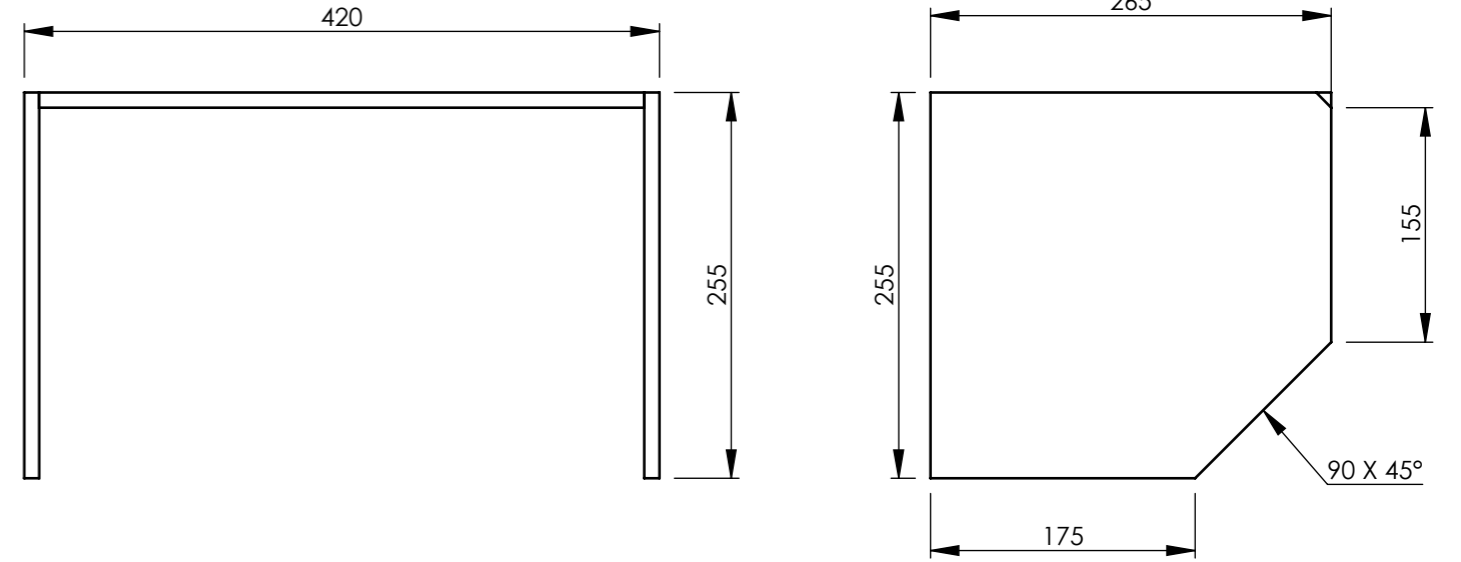

REV	DRAWN	DATE	PARTICULARS
A	AC	23-Apr-19	Created Drawing

ALL TOLERANCES UNLESS OTHERWISE STATED  $\pm 10\text{mm} / \pm 1^\circ$

**Polymaster**  
 161 KARINE STREET  
 SWAN HILL, VIC  
 3585  
 Ph. (03) 5033 9000  
 Fx: (03) 5033 0224

© POLYMASTER GROUP

DESCRIPTION		DO NOT SCALE, USE DIMENSIONS. ALL DIMENSIONS ARE IN mm	
DESCRIPTION	HDPE Cover Plate		
PRODUCT CODE	-		
MATERIAL	HDPE		
COLOUR	BLACK		
LEVEL	AS	DRAWING No.	HDPE COVER-001

A3 SHEET SIZE

SCALE: 1:20

DRAWN AC 23-Apr-19 4/4 Rev: A